

## Top Port Digital Silicon Microphone

### DESCRIPTION

The WM7210 is a low-profile silicon digital microphone. It offers high Signal to Noise Ratio (SNR) and low power consumption and is suited to a wide variety of consumer applications.

The WM7210 incorporates Wolfson's proprietary CMOS/MEMS membrane technology, offering high reliability and high performance in a miniature, low-profile package. The WM7210 is designed to withstand the high temperatures associated with automated flow solder assembly processes. (Note that conventional microphones can be damaged by this process.)

The WM7210 incorporates a high performance ADC, which outputs a single-bit Pulse Density Modulated (PDM) audio data stream. The WM7210 supports selectable left/right channel assignment for a two-channel digital microphone interface, enabling efficient connection of multiple microphones in stereo/array configurations.

The WM7210E variant offers a tighter tolerance on the microphone sensitivity, giving reduced variation between parts. This removes the need for in-line production calibration of part-to-part microphone variations.

### FEATURES

- High SNR; selectable sensitivity tolerance options
  - WM7210 – SNR 58dB, Sensitivity +/-3dB
  - WM7210E – SNR 58dB, Sensitivity +/-1dB
- Low power
  - Sleep mode - 2µA
  - Normal operation - 735µA
- Low profile packaging
- Support for automated flow solder assembly
- PDM digital audio output
- Stereo/array operation
- Proprietary ADC technology
  - Reduced clock jitter sensitivity
  - Low noise floor modulation
  - Stable in overload condition
- Top port package
- 1.64V to 3.7V supply
- 4.00 x 3.00 x 1.03mm thin package design

### APPLICATIONS

- Mobile telephone handsets
- Portable computers
- Portable media players
- Digital still cameras
- Digital video cameras
- Bluetooth headsets
- Portable navigation devices

### BLOCK DIAGRAM

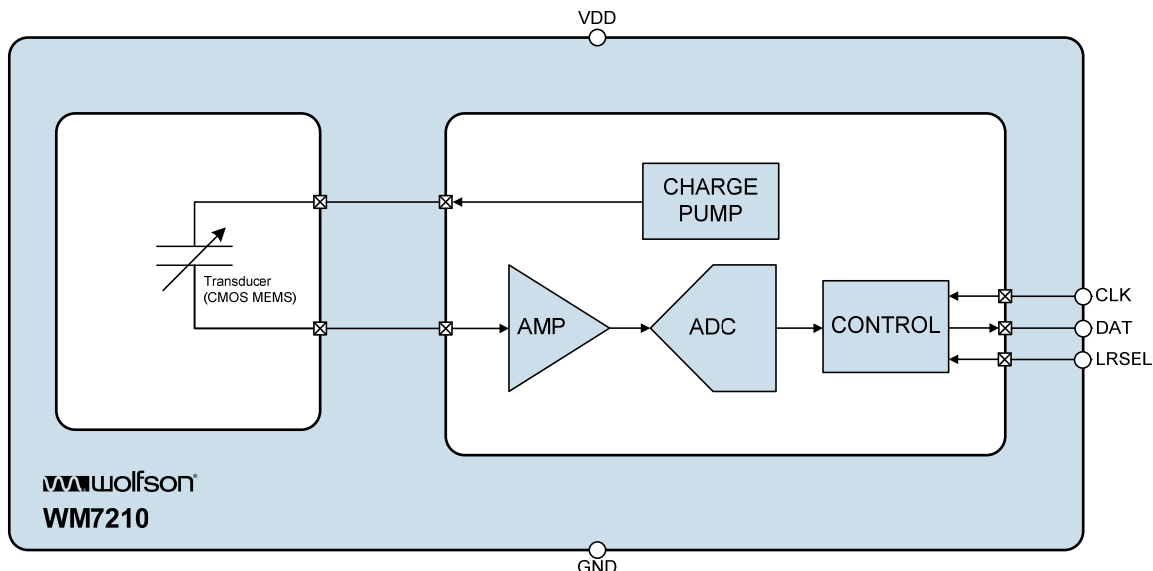

---

**TABLE OF CONTENTS**

<b>DESCRIPTION</b> .....	<b>1</b>
<b>FEATURES</b> .....	<b>1</b>
<b>APPLICATIONS</b> .....	<b>1</b>
<b>BLOCK DIAGRAM</b> .....	<b>1</b>
<b>TABLE OF CONTENTS</b> .....	<b>2</b>
<b>PIN CONFIGURATION</b> .....	<b>3</b>
<b>PIN DESCRIPTION</b> .....	<b>3</b>
<b>ORDERING INFORMATION</b> .....	<b>3</b>
<b>ABSOLUTE MAXIMUM RATINGS</b> .....	<b>4</b>
<b>IMPORTANT ASSEMBLY GUIDELINES</b> .....	<b>4</b>
<b>RECOMMENDED OPERATING CONDITIONS</b> .....	<b>4</b>
<b>ACOUSTIC AND ELECTRICAL CHARACTERISTICS</b> .....	<b>5</b>
TERMINOLOGY .....	6
AUDIO INTERFACE TIMING .....	7
<b>TYPICAL PERFORMANCE</b> .....	<b>8</b>
FREQUENCY RESPONSE .....	8
THD RATIO .....	8
<b>APPLICATIONS INFORMATION</b> .....	<b>9</b>
RECOMMENDED EXTERNAL COMPONENTS .....	9
OPTIMISED SYSTEM RF DESIGN .....	9
CONNECTION TO A WOLFSON AUDIO CODEC .....	9
RECOMMENDED PCB LAND PATTERNS .....	10
<b>PACKAGE DIMENSIONS (LGA)</b> .....	<b>11</b>
<b>IMPORTANT NOTICE</b> .....	<b>12</b>
ADDRESS:.....	12
<b>REVISION HISTORY</b> .....	<b>13</b>

## PIN CONFIGURATION

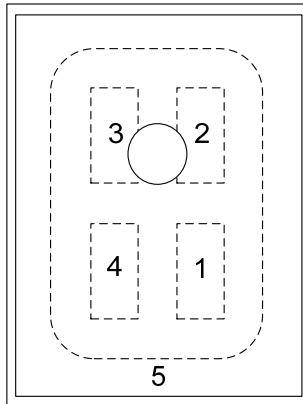

Top View

## PIN DESCRIPTION

PIN	NAME	TYPE	DESCRIPTION
1	VDD	Supply	Supply
2	LRSEL	Digital Input	Channel Select 0 = Data output following falling CLK edge 1 = Data output following rising CLK edge
3	CLK	Digital Input	Clock input
4	DAT	Digital Output	PDM Data Output
5	GND	Supply	Ground

## ORDERING INFORMATION

DEVICE	DESCRIPTION	TEMPERATURE RANGE	MOISTURE SENSITIVITY LEVEL	PEAK SOLDERING TEMPERATURE
WM7210IMS/RV	Standard (tape and reel)	-40 to +100°C	MSL2A	+260°C
WM7210IMSE/RV	Standard Enhanced (tape and reel)	-40 to +100°C	MSL2A	+260°C

**Note:**

Reel Quantity = 4800

All devices are Pb-free and Halogen free.

## ABSOLUTE MAXIMUM RATINGS

Absolute Maximum Ratings are stress ratings only. Permanent damage to the device may be caused by continuously operating at or beyond these limits. Device functional operating limits and guaranteed performance specifications are given under Electrical Characteristics at the test conditions specified.



ESD Sensitive Device. This device is manufactured on a CMOS process. It is therefore generically susceptible to damage from excessive static voltages. Proper ESD precautions must be taken during handling and storage of this device.

Wolfson tests its package types according to IPC/JEDEC J-STD-020 for Moisture Sensitivity to determine acceptable storage conditions prior to surface mount assembly. These levels are:

MSL1 = unlimited floor life at <30°C / 85% Relative Humidity. Not normally stored in moisture barrier bag.

MSL2 = out of bag storage for 1 year at <30°C / 60% Relative Humidity. Supplied in moisture barrier bag.

MSL2A = out of bag storage for 4 weeks at <30°C / 60% Relative Humidity. Supplied in moisture barrier bag.

MSL3 = out of bag storage for 168 hours at <30°C / 60% Relative Humidity. Supplied in moisture barrier bag.

The Moisture Sensitivity Level for each package type is specified in Ordering Information.

CONDITION	MIN	MAX
Supply Voltage (VDD)	-0.3V	+4.2V
Voltage range digital inputs (LRSEL and CLK)	GND-0.3V	VDD+0.3V
Operating temperature range, T <sub>A</sub>	-40°C	+100°C
Storage temperature prior to soldering	30°C max / 60% RH max	
Storage temperature after soldering	-40°C	+100°C

## IMPORTANT ASSEMBLY GUIDELINES

Do not put a vacuum over the port hole of the microphone. Placing a vacuum over the port hole can damage the device. For information on recommended pick and place vacuum point, refer to the package dimension drawing.

Do not board wash the microphone after a re-flow process. Board washing and the associated cleaning agents can damage the device. Do not expose to ultrasonic cleaning methods.

Do not use vapour phase re-flow process. The vapour can damage the device.

Please refer to application note WAN0273 (MEMS MIC Assembly and Handling Guidelines) for further assembly and handling guidelines.

## RECOMMENDED OPERATING CONDITIONS

PARAMETER	SYMBOL	MIN	TYP	MAX	UNIT
Analogue Supply Range	VDD	1.64		3.7	V
Ground	GND		0		V
Clock Frequency	F <sub>CLK</sub>	1		3.25	MHz

## ACOUSTIC AND ELECTRICAL CHARACTERISTICS

Test Conditions: VDD=1.8V, 1kHz test signal, CLK=2.4MHz, T<sub>A</sub> = 25°C

PARAMETER	SYMBOL	TEST CONDITIONS	MIN	TYP	MAX	UNIT
Directivity			Omni-directional			
Polarity (see note)		Positive sound pressure	Decreasing density of 1's			
Sensitivity (WM7210)	S	94dB SPL	-29	-26	-23	dBFS
Sensitivity (WM7210E)	S	94 dB SPL	-27	-26	-25	dBFS
Acoustic Overload		THD < 10%		120		dB SPL
Signal to Noise Ratio	SNR	A-Weighted		58		dB
Total Harmonic Distortion	THD	100dB SPL input		0.1	1	%
Dynamic Range	DR	A-weighted noise floor to 1% THD		81		dB
Frequency response		-3dB Low frequency		35		Hz
		+3dB High frequency		10000		Hz
Acoustic Noise Floor		A-weighted		36		dB SPL
Electrical Noise Floor		A-weighted		-84		dBFS
Power Supply Rejection	PSR	217Hz Square Wave 100mV pk-pk		-65		dBFS
<b>Digital Input / Output</b>						
CLK Input HIGH Level	V <sub>IH</sub>		0.65 x VDD			V
CLK Input LOW Level	V <sub>IL</sub>				0.35 x VDD	V
DAT Output HIGH Level	V <sub>OH</sub>	I <sub>OH</sub> = +1mA	0.9 x VDD			V
DAT Output LOW Level	V <sub>OL</sub>	I <sub>OL</sub> = -1mA			0.1 x VDD	V
Input capacitance (CLK)	C <sub>IN</sub>			0.5		pF
Maximum load capacitance (DAT)	C <sub>LOAD</sub>				100	pF
Input Leakage					1	μA
Short Circuit Output Current	I <sub>SC</sub>	DAT connected to GND			10	mA
<b>Miscellaneous</b>						
Current Consumption	I <sub>VDD</sub>	Active Mode		735		μA
		SLEEP Mode		2	10	
Start-up Time		From OFF		10		ms
		From SLEEP		10		
CLK Sleep Frequency					1.0	kHz

Note: The WM7210 generates a single-bit digital (PDM) output in response to the acoustic input. A positive sound pressure on the diaphragm generates a decreasing density of 1's in the PDM stream (i.e. there is a phase inversion between the acoustic input and the digital output.)

## TERMINOLOGY

1. Sensitivity (dBFS) – Sensitivity is a measure of the microphone output response to the acoustic pressure of a 1kHz 94dB SPL (1Pa RMS) sine wave. This is referenced to the output Full Scale Range (FSR) of the microphone.
2. Full Scale Range (FSR) - Sensitivity, Electrical Noise Floor and Power Supply Rejection are measured with reference to the output Full Scale Range (FSR) of the microphone. FSR is defined as the amplitude of a 1kHz sine wave output whose positive peak value reaches 100% density of logic 1s and whose negative peak value reaches 0% density of logic 1s. This is the largest undistorted 1kHz sine wave that will fit in the digital output numerical range. Note that, because the definition of FSR is based on a sine wave, it is possible to support a square wave test signal output whose level is +3dBFS.
3. Signal-to-Noise Ratio (dB) – SNR is a measure of the difference in level between the output response of a 1kHz 94dB SPL sine wave and the idle noise output.
4. Total Harmonic Distortion (%) – THD is the ratio of the RMS sum of the harmonic distortion products in the specified bandwidth (see note below) relative to the RMS amplitude of the fundamental (ie. test frequency) output.
5. Dynamic Range (dB) - DR is the ratio of the 1% THD microphone output level (in response to a sine wave input) and the idle noise output level.
6. All performance measurements are carried out with 20kHz low pass 'brick-wall' filter and, where noted, an A-weighted filter. Failure to use these filters will result in higher THD and lower SNR values than are found in the Acoustic and Electrical Characteristics. The brick wall filter removes out of band noise.
7. SLEEP Mode is enabled when the CLK input is below the CLK Sleep Frequency noted above. This is a power-saving mode. Normal operation resumes automatically when the CLK input is above the CLK Sleep Frequency. Note that the VDD supply is still required in SLEEP mode.

## AUDIO INTERFACE TIMING

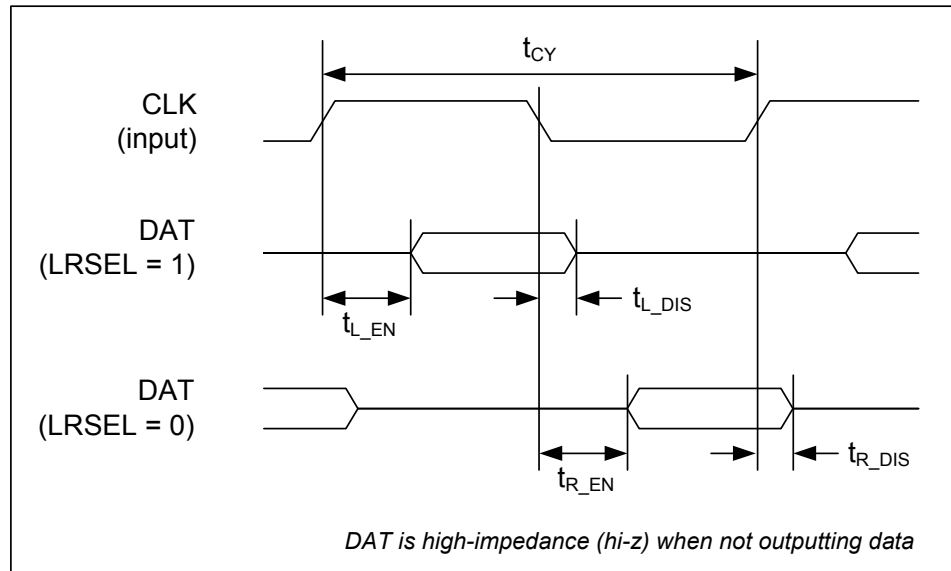

Figure 1 Digital Microphone Interface Timing

## Test Conditions

The following timing information is valid across the full range of recommended operating conditions.

PARAMETER	SYMBOL	MIN	TYP	MAX	UNIT
<b>Digital Microphone Interface Timing</b>					
CLK cycle time	$t_{CY}$	308		1000	ns
CLK duty cycle		60:40		40:60	
DAT enable from rising CLK edge (LRSEL = 1)	$t_{L\_EN}$		18		ns
DAT disable from falling CLK edge (LRSEL = 1)	$t_{L\_DIS}$			16	ns
DAT enable from falling CLK edge (LRSEL = 0)	$t_{R\_EN}$		18		ns
DAT disable from rising CLK edge (LRSEL = 0)	$t_{R\_DIS}$			16	ns

## Notes:

1. The DAT output is high-impedance when not outputting data; this enables the outputs of two microphones to be connected together with the data from one microphone interleaved with the data from the other. (The microphones must be configured to transmit on opposite channels in this case.)
2. In a typical configuration, the Left channel is transmitted following the rising CLK edge (LRSEL = 1). In this case, the Left channel should be sampled by the receiving device on the falling CLK edge,
3. Similarly, the Right channel is typically transmitted following the falling CLK edge (LRSEL = 0). In this case, the Right channel should be sampled by the receiving device on the rising CLK edge.

### TYPICAL PERFORMANCE

### FREQUENCY RESPONSE

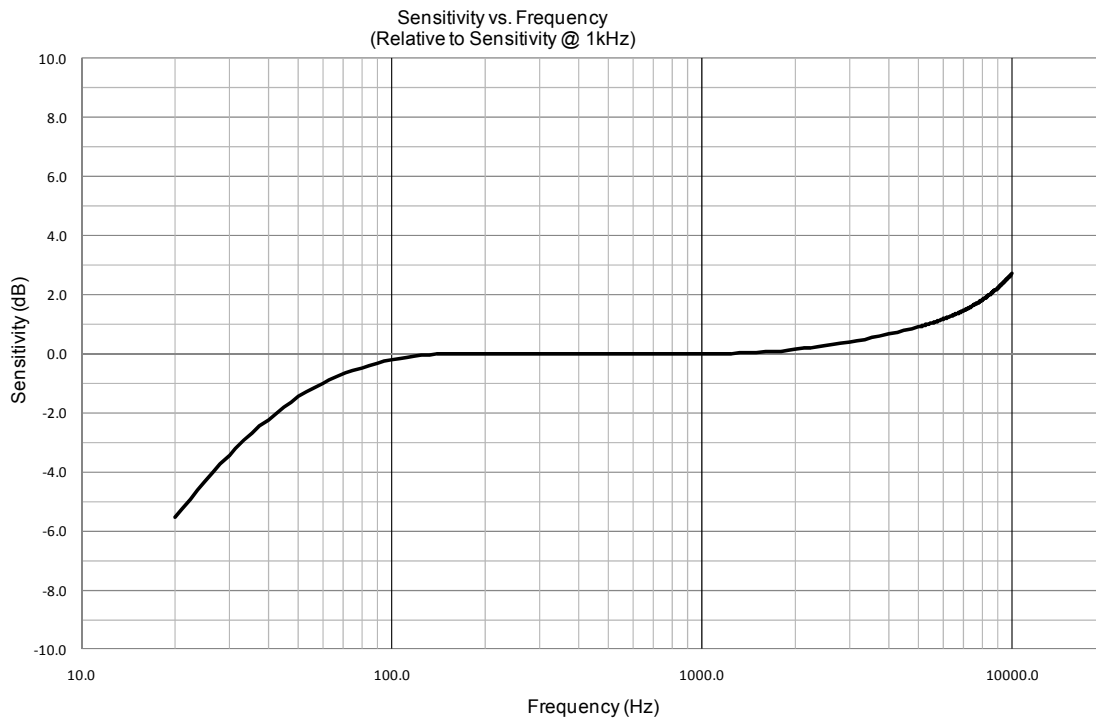

### THD RATIO

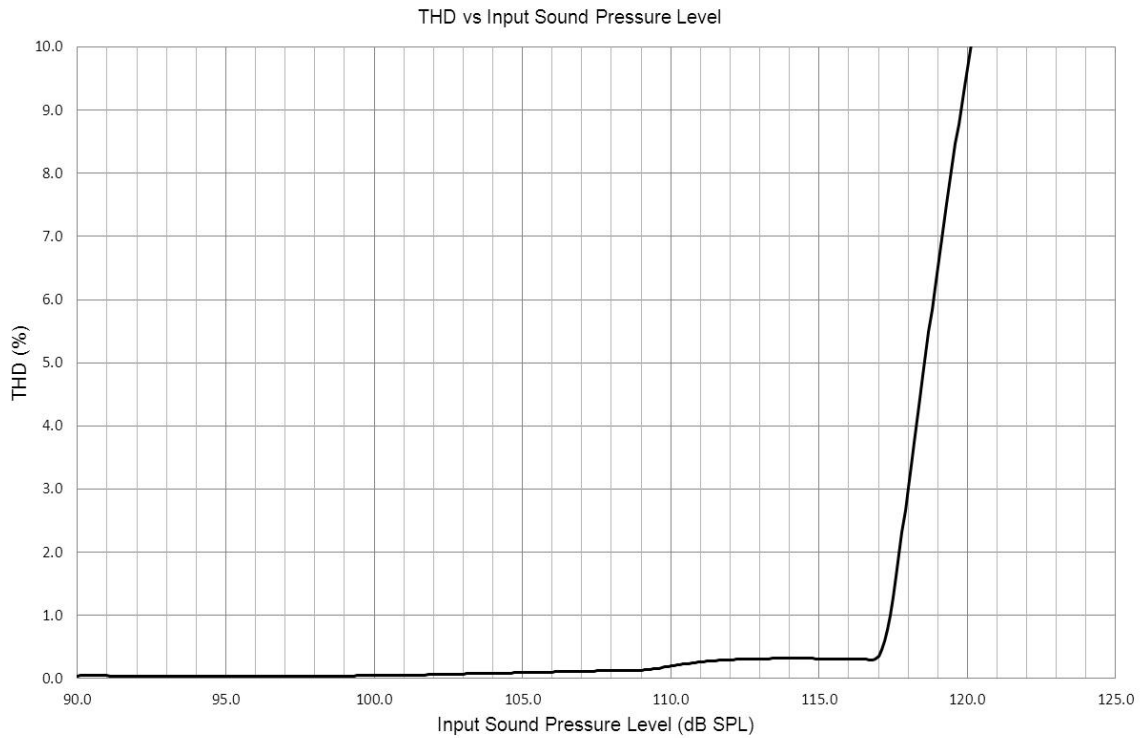



## APPLICATIONS INFORMATION

### RECOMMENDED EXTERNAL COMPONENTS

It is recommended to connect a 0.1 $\mu$ F decoupling capacitor between the VDD and GND pins of the WM7210. A ceramic 0.1 $\mu$ F capacitor with X7R dielectric or better is suitable. The capacitor should be placed as close to the WM7210 as possible.

### OPTIMISED SYSTEM RF DESIGN

For optimised RF design please refer to document WAN0278 (Recommended PCB Layout for Microphone RF Immunity in Mobile Cell Phone Applications) for further information.

### CONNECTION TO A WOLFSON AUDIO CODEC

Wolfson provides a range of audio CODECs incorporating a digital microphone input interface; these support direct connection to digital microphones such as the WM7210.

Stereo connection of two WM7210 digital microphones to the WM8280 CODEC is illustrated in Figure 2.

A 0.1 $\mu$ F decoupling capacitor is recommended; this should be positioned close to the VDD pin of the WM7210. A ceramic 0.1 $\mu$ F capacitor with X7R dielectric or better is suitable.

Further information on the WM8280 is provided in the product datasheet, which is available from the Wolfson website. The equivalent connections can be made to other Wolfson devices supporting a digital microphone interface.

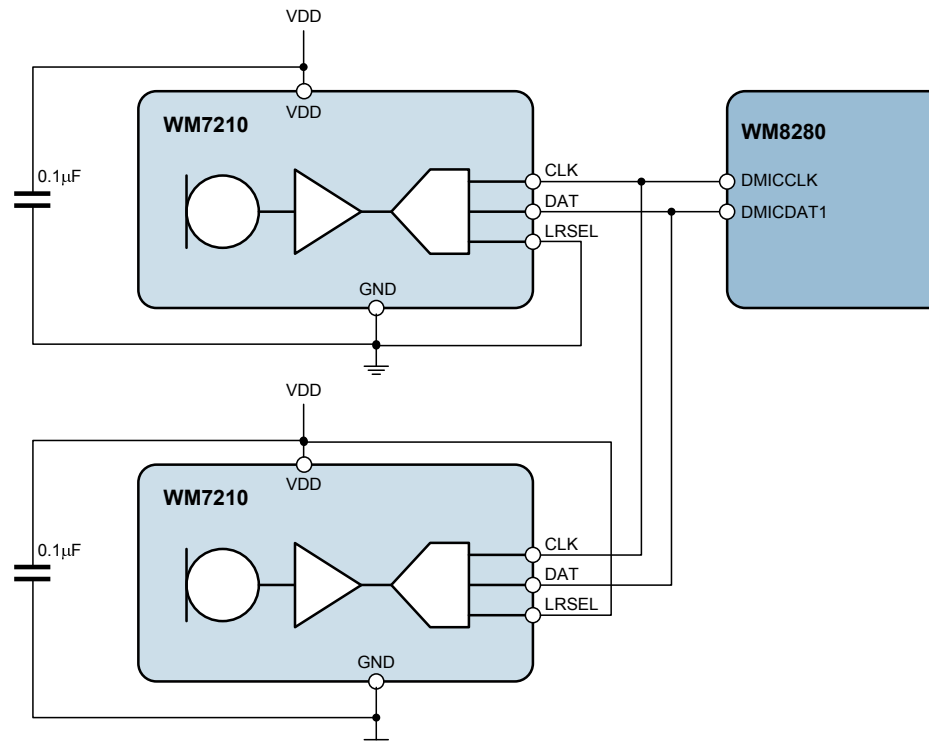

Figure 2 Stereo WM7210 Digital Microphone Connection to WM8280

RECOMMENDED PCB LAND PATTERNS

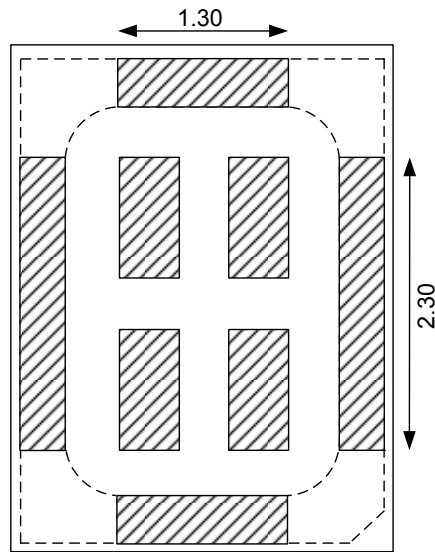
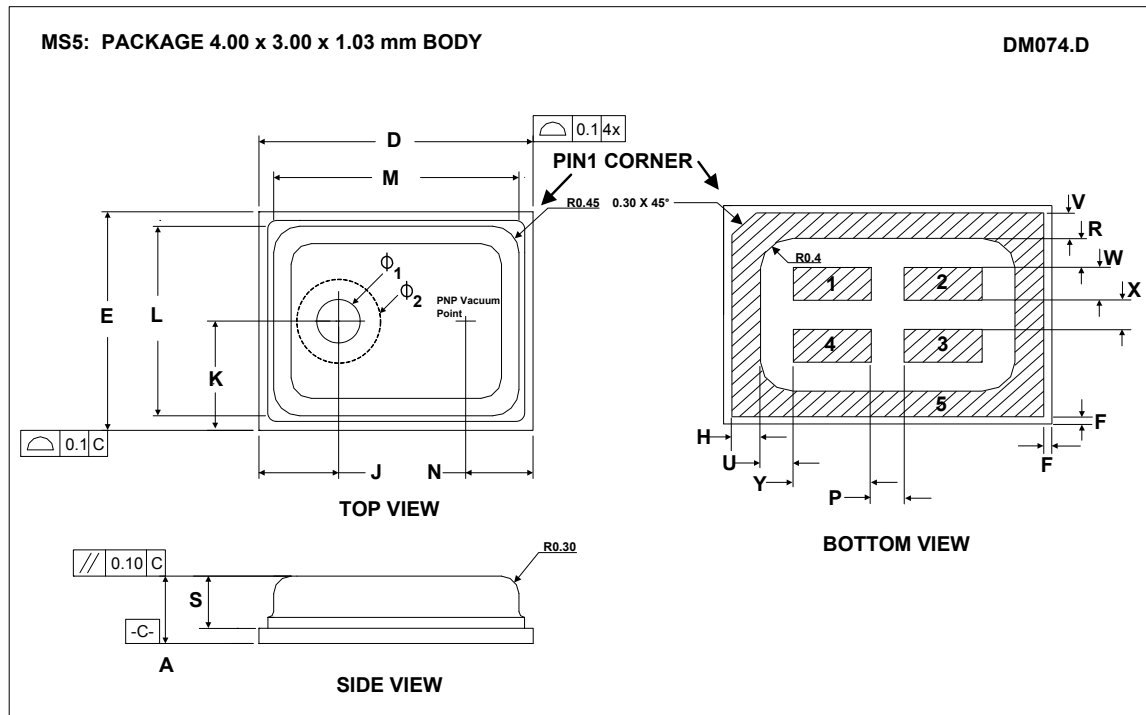

Figure 3 Recommended Customer PCB Land Pattern

(Note that all other dimensions can be obtained from the package dimensions)

**PACKAGE DIMENSIONS (LGA)**



Symbols	Dimensions (mm)			NOTE
	MIN	NOM	MAX	
A	0.96	1.03	1.10	
D	3.90	4.00	4.10	
E	2.90	3.00	3.10	
F	0.05	0.10	0.15	
H	0.30	0.35	0.40	
J	1.35	1.50	1.65	
K	1.35	1.50	1.65	
L		2.55		
M		3.55		
N		1.10		PNP Vacuum Point
P	0.35	0.40	0.45	
R	0.35	0.40	0.45	
S	0.76	0.79	0.82	
U	0.35	0.40	0.45	
V	0.30	0.35	0.40	
W	0.40	0.45	0.50	
X	0.35	0.40	0.45	
Y	0.90	0.95	1.00	
$\phi_1$	0.65	0.70	0.75	
$\phi_2$		1.31		Gasket Area

- NOTES:
1. THE SEATING PLANE IS REPRESENTED BY PRIMARY DATUM -C-
  2. THE DEVIATION FROM THE SEATING PLANE DUE TO WARPAGE OR TWIST IS SPECIFIED AS MAX 100 $\mu$ m (FLATNESS).
  3. LID SHOULD BE PARALLEL TO THE SEATING PLANE  $\pm$ 100 $\mu$ m.

## IMPORTANT NOTICE

Wolfson Microelectronics plc ("Wolfson") products and services are sold subject to Wolfson's terms and conditions of sale, delivery and payment supplied at the time of order acknowledgement.

Wolfson warrants performance of its products to the specifications in effect at the date of shipment. Wolfson reserves the right to make changes to its products and specifications or to discontinue any product or service without notice. Customers should therefore obtain the latest version of relevant information from Wolfson to verify that the information is current.

Testing and other quality control techniques are utilised to the extent Wolfson deems necessary to support its warranty. Specific testing of all parameters of each device is not necessarily performed unless required by law or regulation.

In order to minimise risks associated with customer applications, the customer must use adequate design and operating safeguards to minimise inherent or procedural hazards. Wolfson is not liable for applications assistance or customer product design. The customer is solely responsible for its selection and use of Wolfson products. Wolfson is not liable for such selection or use nor for use of any circuitry other than circuitry entirely embodied in a Wolfson product.

Wolfson's products are not intended for use in life support systems, appliances, nuclear systems or systems where malfunction can reasonably be expected to result in personal injury, death or severe property or environmental damage. Any use of products by the customer for such purposes is at the customer's own risk.

Wolfson does not grant any licence (express or implied) under any patent right, copyright, mask work right or other intellectual property right of Wolfson covering or relating to any combination, machine, or process in which its products or services might be or are used. Any provision or publication of any third party's products or services does not constitute Wolfson's approval, licence, warranty or endorsement thereof. Any third party trade marks contained in this document belong to the respective third party owner.

Reproduction of information from Wolfson datasheets is permissible only if reproduction is without alteration and is accompanied by all associated copyright, proprietary and other notices (including this notice) and conditions. Wolfson is not liable for any unauthorised alteration of such information or for any reliance placed thereon.

Any representations made, warranties given, and/or liabilities accepted by any person which differ from those contained in this datasheet or in Wolfson's standard terms and conditions of sale, delivery and payment are made, given and/or accepted at that person's own risk. Wolfson is not liable for any such representations, warranties or liabilities or for any reliance placed thereon by any person.

### ADDRESS:

Wolfson Microelectronics plc  
Westfield House  
26 Westfield Road  
Edinburgh  
EH11 2QB

Tel :: +44 (0)131 272 7000

Fax :: +44 (0)131 272 7001

Email :: [sales@wolfsonmicro.com](mailto:sales@wolfsonmicro.com)

**REVISION HISTORY**

DATE	REV	ORIGINATOR	CHANGES
25/09/09	1.0		
5/3/10	1.1		
25/10/10	2.0		
27/1/11	2.1	PH	'Top Port' added to device title ENL abbreviation deleted from Electrical Characteristics Acoustic and Electrical Characteristics terminology updated Decoupling capacitor requirement described in 'Connection to a Wolfson Audio CODEC' section
21/2/11	2.1	KC	Updated the LRSEL pin description , Timing diagram and notes for the rising and falling clock edges. Updated the reel quantity. Updated the start up time. Updated the input capacitance Updated the sleep mode current 2uA as typical value Added new frequency response curve Updated the acoustic Characteristics(+3dB frequency response, acoustic noise floor, PSR to -ve value) Updated the frequency response and THD curves.
06/09/11	2.1	JMacD	Package Diagram updated to DM074C with additional tolerance and chamfer detail.
20/12/11	2.2	KC	Introduced E variant with sensitivity +/-1dB Added E variant ordering info Added voltage range digital input Updated the CODEC to WM8994 Added Reference to WAN_0273
28/02/12	3.1	KC	Product status changed to pre-production. Current consumption updated to 700uA
16/10/12	3.2	MR	Package Diagram updated. Note added to Recommended Operating Conditions. Dynamic range added to acoustic characteristics.
18/12/13	3.3	MR	Acoustic and Electrical Characteristics updated: Polarity and Note added.
18/12/13	3.3	MR	Updated CODEC to WM8280